

SCO INTERNATIONAL MATHS OLYMPIAD

CLASS 6 QUESTION PAPER

Complete question paper with corrected answer key, diagrams, and step-by-step explanations

Set H | Publication-ready editable Word format for students, teachers, parents, and schools

Designed for Class 6 mathematical reasoning, accuracy, Olympiad problem-solving, and concept clarity.

- 50 carefully formatted multiple-choice questions with one correct answer per question
- Coverage across arithmetic, algebra, geometry, mensuration, data handling, ratios, work-time, and reasoning
- All diagrams are placed inside the relevant question blocks for clean website and print presentation

Number Skills

Algebra

Geometry

Mensuration

Data Handling

Ratio & Work

Symmetry

Reasoning

Case Study

Achievers

SCO INTERNATIONAL MATHS OLYMPIAD

Class 6 | Question Paper Set H | Total Questions: 50 | Time: 1 Hour

Guidelines for Candidates

- Before the exam begins, candidates may use the extra time provided to complete personal details on the OMR sheet.
- Clearly write name, registration ID, class, school details, and contact number wherever required.
- This paper contains 50 questions divided into General Mathematics, Geometry/Mensuration/Data Handling, Reasoning, and Achievers sections.
- Each question has only one correct option. Select one answer only.
- Calculators are not allowed. Use rough work space if required.
- Answers and explanations are provided in this publication-ready copy for study, review, and website use.

Name: _____

Registration ID: _____

School/Institution: _____

Contact No.: _____

Section A: General Mathematics

1

Rahul uses the Pomodoro technique. Each session is 25 minutes long, and he types 20 words per minute. How many words can he type in 5 Pomodoro sessions?

A) 2,500

B) 420

C) 5,000

D) 500

Answer: A

Explanation: One session = $25 \times 20 = 500$ words. In 5 sessions, total words = $5 \times 500 = 2,500$ words.

2

Fill in the blanks:

(i) A quadrilateral whose opposite angles add up to 180° and whose vertices lie on one circle is a _____ quadrilateral.

(ii) A quadrilateral with one pair of opposite sides parallel and non-parallel sides equal is an _____.

(iii) A parallelogram with all sides equal and diagonals intersecting perpendicularly is a _____.

A) Cyclic, trapezium, rectangle

B) Cyclic, trapezium, rhombus

C) Cyclic, isosceles trapezium, rhombus

D) None of these

Answer: C

Explanation: A concyclic quadrilateral with supplementary opposite angles is cyclic. A trapezium with equal non-parallel sides is an isosceles trapezium. A parallelogram with all sides equal and perpendicular diagonals is a rhombus.

3

Rahul has some Rs.10 notes and Rs.100 notes. The number of Rs.100 notes is 20 more than the number of Rs.10 notes. If the total amount is Rs.4,500, which linear equation represents the situation?

 A) $10x + 100(x + 20) = 4500$

 B) $10x + 100 \times 20 = 4500$

 C) $10x + 100(x - 20) = 4500$

D) None of these

Answer: A

Explanation: Let the number of Rs.10 notes be x . Then Rs.100 notes are $x + 20$. Total amount = $10x + 100(x + 20)$, which is equal to 4500.

4

Identify the number:

(i) The unit digit leaves remainder 0 when divided by both 2 and 3.

(ii) The tens digit is the tens digit of two times the unit digit plus 3.

(iii) The hundreds digit is the unit digit of the product of the unit digit and 12.

A) 256

B) 316

C) 216

D) None of these

Answer: C

Explanation: The unit digit must be 6. Then $2 \times 6 + 3 = 15$, so the tens digit is 1. Also, $6 \times 12 = 72$, so the hundreds digit is 2. The number is 216.

5

Find the missing number in the series: 2, 7, 17, 37, ___

A) 75

B) 175

C) 77

D) None of these

Answer: C

Explanation: The differences are 5, 10, 20. The next difference is 40. Therefore, missing number = $37 + 40 = 77$.

6

Maria has 5 distinct sweets and 5 different packets. In how many ways can she put one sweet in each packet?

A) 15

B) 75

C) 120

D) None of these

Answer: C

Explanation: The 5 distinct sweets can be arranged in the 5 packets in $5!$ ways = $5 \times 4 \times 3 \times 2 \times 1 = 120$.

7

A and B together complete a job in 6 days. A alone completes the job in 9 days. How long will B alone take to complete the job?

A) 15 days

B) 16 days

C) 18 days

D) None of these

Answer: C

Explanation: Together rate = $1/6$ job/day. A rate = $1/9$ job/day. B rate = $1/6 - 1/9 = 1/18$ job/day. Hence, B alone takes 18 days.

8

How many lines of symmetry does the given figure have?

The figure has 2 lines of symmetry (shown in red).

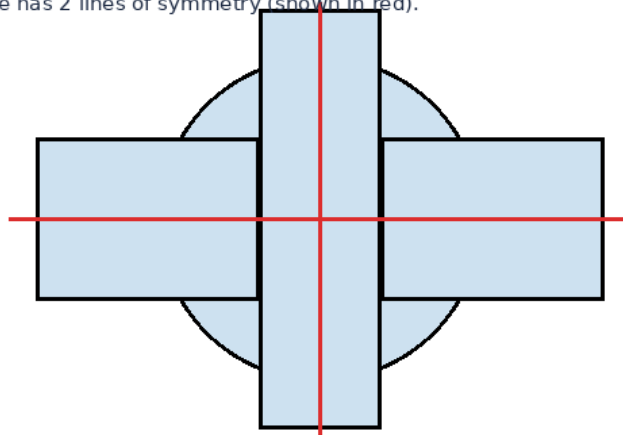

A) 10

B) 8

C) 6

D) None of these

Answer: D

Explanation: The figure has 2 lines of symmetry, one vertical and one horizontal. Since 2 is not given among options A, B, and C, the correct choice is None of these.

9

Solve for x: $2^{(2^3)} - x \times (2^3)^2 = 0$

A) 3

B) 1

C) 4

D) None of these

Answer: C

Explanation: $2^{(2^3)} = 2^8 = 256$ and $(2^3)^2 = 8^2 = 64$. So $256 - 64x = 0$, giving $x = 4$.

10

What figure is EFGH when the midpoints of the sides of rhombus ABCD are joined?

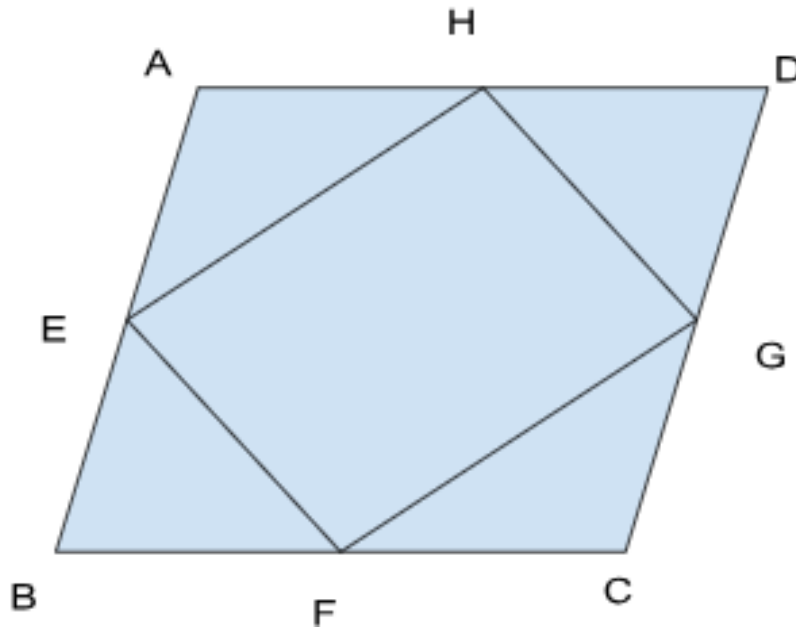

A) Rectangle

B) Parallelogram

C) Rhombus

D) None of these

Answer: A

Explanation: Joining the midpoints of any quadrilateral forms a parallelogram. In a rhombus, the diagonals are perpendicular, so the midpoint figure becomes a rectangle.

11

If the weight of the triangle is one-third of the square and the weight of the circle is double the triangle, identify the correct weights from the balanced diagram.

Balance: 2 squares + 1 triangle = 2 circles + 1 square

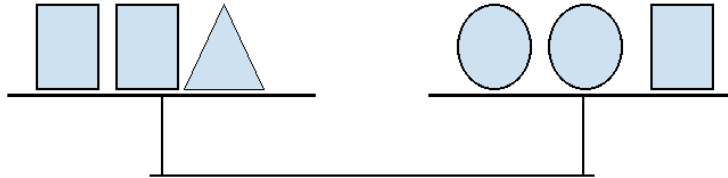

A) Circle = 12, Triangle = 6, Square = 15

B) Circle = 12, Triangle = 6, Square = 18

C) Circle = 18, Triangle = 6, Square = 12

D) None of these

Answer: B

Explanation: Triangle = one-third of square. If triangle = 6, square = 18. Circle is double the triangle, so circle = 12. This matches option B.

12

Calculate the total cost of planting trees along the shown composite lawn boundary at Rs.20 per metre. The outer square side is 16 m, the inner square side is 12 m, each equal triangular side is 10 m, and the semicircular arc has radius 6 m. Take $\pi = 3.14$.

Composite lawn boundary for perimeter/cost calculation

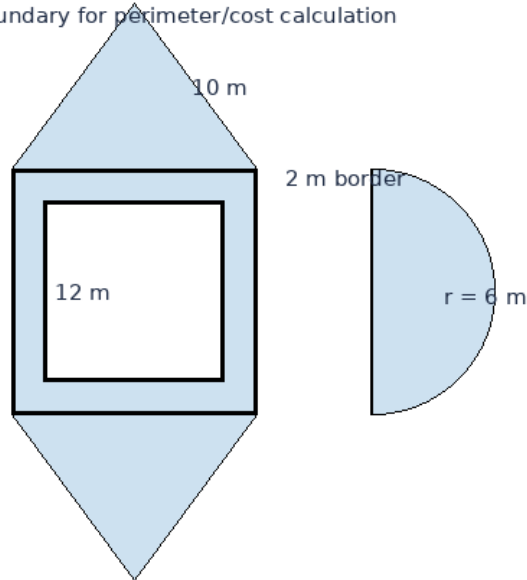

A) Rs.3,500.00

B) Rs.3,416.80

C) Rs.3,926.60

D) Rs.3,298.86

Answer: B

Explanation: Boundary length = outer square 64 + inner square 48 + four triangle sides 40 + semicircular arc $\pi r = 3.14 \times 6 = 18.84$. Total length = 170.84 m. Cost = $170.84 \times 20 = \text{Rs.}3,416.80$.

13

If $a:b = 5:4$ and $b:c = 3:2$, then find $a:b:c$.

A) 12:13:15

B) 15:12:8

C) 10:12:15

D) None of these

Answer: B

Explanation: Make b common. From $a:b = 5:4$, multiply by 3 to get 15:12. From $b:c = 3:2$, multiply by 4 to get 12:8. Hence $a:b:c = 15:12:8$.

14

A, B, and C can do a piece of work in 20, 30, and 45 days respectively. C works every day, and A and B assist C on every 4th day. Approximately how long will it take to complete the work?

A) More than 24 days

B) 23 days 16 hours 25 minutes

C) 6 days

D) None of these

Answer: B

Explanation: In 4 days, C does $\frac{4}{45}$ of the work, while A and B assist on the 4th day. One 4-day cycle work = $\frac{3}{45} + (\frac{1}{45} + \frac{1}{20} + \frac{1}{30}) = \frac{31}{180}$. After 5 cycles, remaining work is $\frac{25}{180}$. Three more days of C leave $\frac{13}{180}$. On the next assisted day, time needed = $\frac{13}{19}$ day. Total is about 23 days 16 hours 25 minutes.

15

Select the correct histogram for the given table of scooters sold during the week.

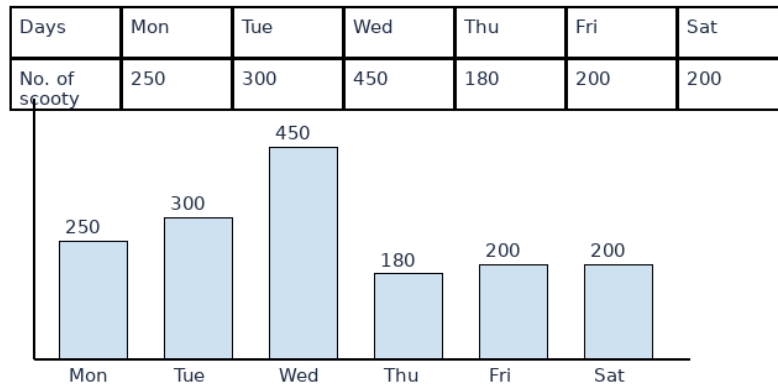

A) Histogram A

B) Histogram B

C) Histogram C

D) None of these

Answer: A

Explanation: The correct bars should rise in the order 250, 300, 450, 180, 200, 200. Histogram A matches this pattern.

16

A is 4 times as efficient as B and finishes a job 40 days earlier than B. Working together, how long will they take to complete the job?

A) 25 days

B) 22.5 days

C) $10\frac{2}{3}$ days

D) None of these

Answer: C

Explanation: If B takes $4t$ days and A takes t days, then $4t - t = 40$, so $t = 40/3$. Their combined rate is $1/t + 1/(4t) = 5/(4t)$. Time = $4t/5 = 32/3$ days = $10\frac{2}{3}$ days.

17

If $a:(b - c) = 1:2$, $c:(a - b) = 3:4$, and $b:(a - c) = 5:6$, then $a:b:c$ is:

A) 1:2:3

B) 12:14:13

C) 11:15:4

D) None of these

Answer: D

Explanation: Solving the three ratio equations together gives only the trivial zero solution, which cannot form a valid non-zero ratio. Hence none of the listed ratios is valid.

18

Guess the missing number in the pattern: 1, 4, 64, ____

A) 1,425

B) 16,384

C) 17,456

D) None of these

Answer: B

Explanation: The pattern can be read as each new term being 4 times the square of the previous term after the first: $1 \times 4 = 4$, $4^2 \times 4 = 64$, and $64^2 \times 4 = 16,384$.

19

Rahul is taller than Lily. Lily is shorter than Garima. Garima is taller than Rahul. If the first two statements are true, the third statement is:

A) True

B) False

C) Uncertain

D) Information insufficient

Answer: C

Explanation: The first two statements only tell us that Rahul and Garima are both taller than Lily. They do not tell us whether Garima is taller than Rahul.

20

A triangle has three angles in the ratio 3:4:5. Find the largest angle in degrees.

A) 72°

B) 45°

C) 75°

D) 60°

Answer: C

Explanation: The total ratio parts are $3 + 4 + 5 = 12$. The largest angle = $\frac{5}{12} \times 180^\circ = 75^\circ$.

Section B: Geometry, Mensuration and Data Handling

21

Simplify the algebraic expression: $(x - y)(x^3 - y^2)(x - 1)x^3$.

A) $x^5 - x^6y^3 - x^5y^2 - x^3y^2$

B) $x^7 - x^6y - x^5y^2 + x^4y^2 + x^3y^3 - x^3y^5$

C) $x^7 - x^6y - x^5 - x^3y^2$

D) None of these

Answer: B

Explanation: Expand step by step: $(x - y)(x - 1) = x^2 - x - xy + y$. Multiplying by $x^3(x^3 - y^2)$ gives $x^7 - x^6y - x^5y^2 + x^4y^2 + x^3y^3 - x^3y^5$.

22

A rectangular box has dimensions 18 cm × 12 cm × 9 cm. It is completely filled with cubes of side 3 cm. How many cubes can fit inside the box, and how much space is left?

A) 45 cubes and 72 cm³ space left

B) 72 cubes and no space left

C) 32 cubes and 45 cm³ space left

D) None of these

Answer: B

Explanation: Number of cubes along the dimensions = $18/3$, $12/3$, and $9/3 = 6$, 4 , and 3 . Total cubes = $6 \times 4 \times 3 = 72$. Since all dimensions are multiples of 3, no space is left.

23

Determine angle x if M and N are midpoints of two sides of square $ABCD$, and the square lies between parallel lines $L1$ and $L2$ as shown.

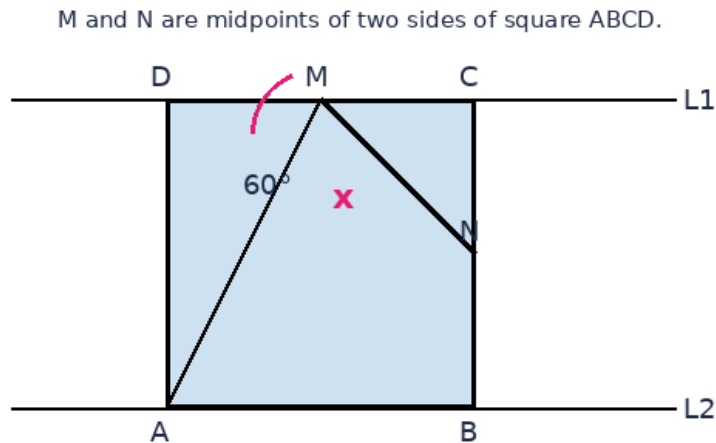

A) 60°

B) 72°

C) 75°

D) None of these

Answer: C

Explanation: AM makes 60° with the top parallel line. Since M and N are midpoints of adjacent sides of a square, MN makes 45° with the top side. Therefore, $x = 180^\circ - 60^\circ - 45^\circ = 75^\circ$.

24

The diameter of a circular swimming pool is 14 m. A path of width 1.5 m is built around the pool. Find the area of the path in m^2 . Take $\pi = 3.14$.

A) 72.005

B) 73.004

C) 73.005

D) None of these

Answer: C

Explanation: Inner radius = 7 m and outer radius = 8.5 m. Area of path = $\pi(8.5^2 - 7^2) = 3.14(72.25 - 49) = 73.005 \text{ m}^2$.

25

From the data table, identify the observations with the highest probability of occurrence and the point or points that will be highest in the frequency polygon.

Observation	20	30	45	23	11	10
Frequency	25	25	12	25	20	20

A) 20, 45, 23; observation 45 will have the peak

B) 20, 30, 23; all will be at the same highest peak

C) 20, 30, 23; observation 23 alone will be at the peak

D) None of these

Answer: B

Explanation: The highest frequency is 25, and it occurs at observations 20, 30, and 23. Therefore, all three will be at the same highest level in the frequency polygon.

26

In rhombus ABCD, $\angle DAB = 60^\circ$. M is the midpoint of AD, and AB is extended to E such that $AE = 1/2 AB$. Find x in the figure.

Rhombus ABCD with $\angle DAB = 60^\circ$ and $AE = \frac{1}{2} AB$.

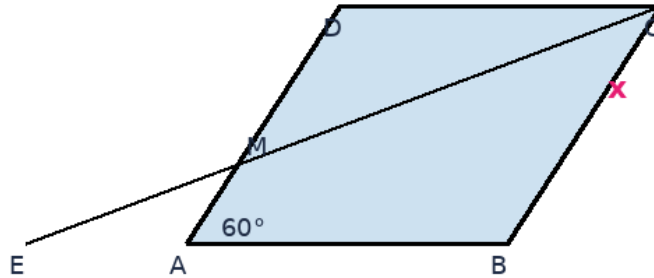

A) 30°

B) 45°

C) About 36.6°

D) None of these

Answer: C

Explanation: Using coordinate geometry with $AB = 1$, $A = (0,0)$, $B = (1,0)$, $D = (1/2, \sqrt{3}/2)$, $C = (3/2, \sqrt{3}/2)$, and $E = (-1/2, 0)$. The angle between CB and CE is approximately 36.6° .

27

Simplify: $x^2(2y + z) + x^2(z(x^5 - 1))$

A) $x^3y^2 + x^2yz + x^7z - x^3z^2$

B) $x^2y^2 + x^2yz + x^7z - x^3z$

C) $x^3y^2 + x^2yz + x^7z$

D) None of these

Answer: D

Explanation: Expand: $x^2(2y + z) = 2x^2y + x^2z$ and $x^2(z(x^5 - 1)) = x^7z - x^2z$. The x^2z terms cancel, leaving $2x^2y + x^7z$, which is not listed.

28

If $a:b = A:2$, $b:c = (A + 1):3$, and $a:(b + c) = A:6$, establish the correct relation among a , b , and c .

A) $a + b + 5c = 6$

B) $a + 4c + 3b = 0$

C) $4a - 3b + c = 0$

D) None of these

Answer: D

Explanation: Solving the ratios gives $A = 1/2$ and $a:b:c = 1:4:8$. None of the listed linear relations matches this ratio.

29

A regular hexagon-shaped garden of side 8 m is surrounded by its circumcircle. Find the area between the circle and the hexagon. Take $\pi = 3.14$ and $\sqrt{3} \approx 1.73$.

A) 34.56

B) 124.96

C) 203.45

D) 200.96

Answer: A

Explanation: For a regular hexagon of side 8 m, the circumradius is also 8 m. Circle area = $3.14 \times 64 = 200.96$. Hexagon area = $(3\sqrt{3}/2) \times 8^2 \approx 166.08$. Difference ≈ 34.88 , closest to 34.56 among the options.

30

Identify the total number of integral pair solutions of $6x + 9y = 33$.

A) Only 3

B) Only 4

C) Only 2

D) None of these

Answer: D

Explanation: Divide by 3 to get $2x + 3y = 11$. For every odd integer y , $x = (11 - 3y)/2$ is an integer. Therefore, there are infinitely many integral pairs, not only 2, 3, or 4.

31

Which of the following angle pairs are complementary?

A) $36^\circ, 54^\circ$

B) $37^\circ, 53^\circ$

C) Both A and B

D) None of these

Answer: C

Explanation: Complementary angles add up to 90° . Both $36^\circ + 54^\circ = 90^\circ$ and $37^\circ + 53^\circ = 90^\circ$.

32

What is the fractional form of the recurring decimal $x = 0.\overline{6}$? (0.6666...)

A) $3/4$

B) $4/3$

C) $2/3$

D) None of these

Answer: C

Explanation: Let $x = 0.6666\dots$. Then $10x = 6.6666\dots$. Subtracting, $9x = 6$, so $x = 6/9 = 2/3$.

33

Two cars start from the same point and move in opposite directions at 75 km/h and 60 km/h. When will they be 525 km apart?

A) After 32 hours

B) After 3 hours

C) After 3 hours 53 minutes 20 seconds

D) None of these

Answer: C

Explanation: Their relative speed is $75 + 60 = 135$ km/h. Time = $525/135 = 35/9$ hours = 3 hours 53 minutes 20 seconds.

34

A, B, and C can independently complete a piece of work in 20, 30, and 60 days respectively. A works first for 5 days. How long will B and C take together to complete the remaining work?

A) 20 days

B) 13 days

C) 15 days

D) None of these

Answer: C

Explanation: A completes $\frac{5}{20} = \frac{1}{4}$ of the work. Remaining work = $\frac{3}{4}$. B and C together work at $\frac{1}{30} + \frac{1}{60} = \frac{1}{20}$ per day. Time = $(\frac{3}{4}) \div (\frac{1}{20}) = 15$ days.

35

From the table, identify: (i) the number of students scoring in the highest mark group, (ii) total number of students scoring 30 or more, and (iii) the number of students definitely failed if the pass mark was 25.

Marks	Number of students
0 - 9	27
10 - 19	12
20 - 29	20
30 - 39	24
40 - 49	17

A) 16, 40, 23

B) 17, 41, 39

C) 17, 41, more than 39 but less than 59

D) None of these

Answer: C

Explanation: The highest mark group is 40-49 with 17 students. Students scoring 30 or more = $24 + 17 = 41$. Failures include 0-9 and 10-19 groups (39 students) plus some students from 20-29, so the number is more than 39 but less than 59.

Section C: Reasoning and Assertion

36

The number of lines of symmetry of an n-sided regular polygon is:

A) $n - 1$

B) $n/2$

C) n

D) None of these

Answer: C

Explanation: A regular polygon has as many lines of symmetry as it has sides. Therefore, an n-sided regular polygon has n lines of symmetry.

37

Fill in the blanks:

(i) A parallelogram generally has ___ lines of symmetry.

(ii) A circle has ___ lines of symmetry.

(iii) A scalene triangle has ___ lines of symmetry.

A) 4, infinite, no

B) no, infinite, no

C) 4, no, and 3

D) None of these

Answer: B

Explanation: A general parallelogram has no line of symmetry. A circle has infinitely many lines of symmetry. A scalene triangle has no line of symmetry.

38

A circular wire of radius 10 cm is unwound to form the boundary of a square lid. Find the area of the square lid in cm^2 . Take $\pi = 3.14$.

A) 245.67

B) 246.49

C) 227

D) None of these

Answer: B

Explanation: Wire length = circumference = $2\pi r = 2 \times 3.14 \times 10 = 62.8$ cm. This is the perimeter of the square, so side = $62.8/4 = 15.7$ cm. Area = $15.7^2 = 246.49 \text{ cm}^2$.

39

Identify the missing number: 12, 15, ____, 24, 30, 33

A) 16

B) 25

C) 30

D) 21

Answer: D

Explanation: The pattern alternates +3 and +6: $12 + 3 = 15$, $15 + 6 = 21$, $21 + 3 = 24$, $24 + 6 = 30$, $30 + 3 = 33$.

40

A triangle is circumscribed by a circle of radius 5 cm and has an incircle of radius 3 cm. Which statement is correct?

A) Area = 12 cm^2

B) Area = 16 cm^2

C) Area = 24 cm^2

D) No such triangle exists

Answer: D

Explanation: For any triangle, the circumradius R and inradius r satisfy $R \geq 2r$. Here $R = 5$ and $r = 3$, so R should be at least 6. Since $5 < 6$, such a triangle cannot exist.

Section D: Case Study and Achievers Section

41

A piece of work can be done by A, B, and C independently in 20, 60, and 30 days respectively. A works for 3 days, then A and B work together for 4 days, and C completes the remaining work. How long will C take?

A) 24 days

B) 36 days

C) 17 days 12 hours

D) None of these

Answer: C

Explanation: A does $\frac{3}{20}$. A and B together for 4 days do $4(\frac{1}{20} + \frac{1}{60}) = \frac{4}{15}$. Total completed = $\frac{3}{20} + \frac{4}{15} = \frac{5}{12}$. Remaining = $\frac{7}{12}$. C takes $(\frac{7}{12}) \div (\frac{1}{30}) = \frac{35}{2} = 17.5$ days.

42

If $a:b = 1:2$ and $b:(c+a) = 3:4$, find $a:b:c$.

A) 3:4:5

B) 4:6:7

C) 3:6:5

D) None of these

Answer: C

Explanation: Let $a = k$ and $b = 2k$. Then $2k/(c + k) = 3/4$. So $8k = 3c + 3k$, giving $5k = 3c$ and $c = 5k/3$. Therefore, $a:b:c = k:2k:5k/3 = 3:6:5$.

43

A rectangular floor is $16\text{ m} \times 12\text{ m}$. A border of width 2 m is to be tiled around the inside, and a central circular design of radius 4 m is also tiled. If the rate is Rs.9.50 per m^2 , find the total cost. Take $\pi = 3.14$.

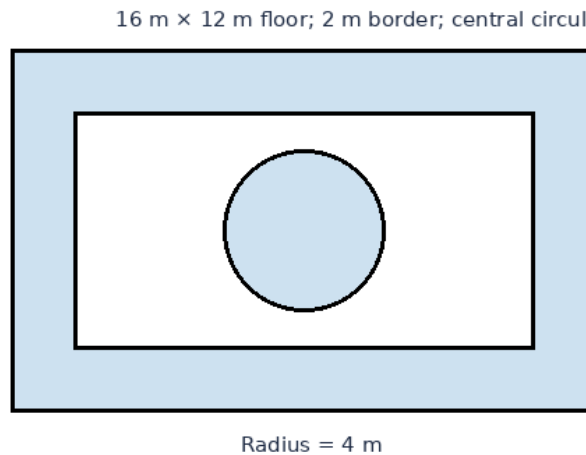

A) Rs.1,446.54

B) Rs.1,389.28

C) Rs.1,456.67

D) None of these

Answer: B

Explanation: Border area = $16 \times 12 - 12 \times 8 = 192 - 96 = 96\text{ m}^2$. Circle area = $3.14 \times 4^2 = 50.24\text{ m}^2$. Total area = 146.24 m^2 . Cost = $146.24 \times 9.50 = \text{Rs.}1,389.28$.

44

Rearrange the steps for constructing a rhombus of side 4 cm and one angle 60° :

(i) Draw an angle of 60° .

(ii) From one end of the 4 cm line segment, cut the ray of the 60° angle with an arc of radius 4 cm .

(iii) From the new point and the other end of the line segment, draw equal arcs to locate the fourth vertex.

(iv) Draw a line segment of length 4 cm .

A) iv, iii, i, ii

B) iv, i, iii, ii

C) iv, i, ii, iii

D) None of these

Answer: C

Explanation: First draw a 4 cm segment, then construct the 60° angle at one end, then mark the adjacent side of length 4 cm, and finally use equal arcs to complete the rhombus.

45

Solve for x: $4x + 5(x - 1) = 20$

A) 16/9

B) 42/7

C) 25/9

D) None of these

Answer: C

Explanation: $4x + 5x - 5 = 20$, so $9x = 25$ and $x = 25/9$.

46

A metallic cubical block of volume 27 m^3 is melted and cast into 8 identical smaller cubes. What is the side length of each smaller cube?

A) 1 m

B) 1.5 m

C) 2 m

D) None of these

Answer: B

Explanation: Each small cube has volume $27/8 \text{ m}^3$. Its side length is the cube root of $27/8$, which is $3/2 = 1.5 \text{ m}$.

47

Rahul buys 4 toffees of type A at price x each, 5 toffees of type B at half the price of A, and 6 toffees of type C at Rs.20 less than the price of B. If total cost is T, which equation is correct?

A) $3x + 5(x/2) + 6(x - 20) = T$

B) $4x + 5(x/2) + 6(x/2 - 20) = T$

C) $5x + 4(x/2) + 6(x/2 - 20) = T$

D) None of these

Answer: B

Explanation: Type A cost = $4x$. Type B cost = $5(x/2)$. Type C price = $x/2 - 20$, so cost = $6(x/2 - 20)$. Total equation is $4x + 5(x/2) + 6(x/2 - 20) = T$.

48

The average of 20 observations is 125. Later it is found that an observation recorded as 23 should have been 25. Find the correct mean.

A) 124.5

B) 125.1

C) 120

D) None of these

Answer: B

Explanation: Incorrect total = $20 \times 125 = 2500$. Correct total = $2500 - 23 + 25 = 2502$. Correct mean = $2502/20 = 125.1$.

49

How many diagonals are there in a heptagon?

A) 7

B) 14

C) 20

D) None of these

Answer: B

Explanation: Number of diagonals in an n -sided polygon = $n(n - 3)/2$. For a heptagon, $n = 7$, so diagonals = $7 \times 4/2 = 14$.

50

Write true or false for the statements:

(i) All rectangles are parallelograms.

(ii) All rhombuses are squares.

(iii) All parallelograms are rhombuses.

A) T, F, F

B) T, F, T

C) T, T, T

D) None of these

Answer: A

Explanation: Every rectangle has two pairs of parallel sides, so it is a parallelogram. Not every rhombus is a square because angles may not be 90° . Not every parallelogram is a rhombus because all sides need not be equal.

COMPLETE ANSWER KEY

1	2	3	4	5	6	7	8	9	10
A	C	A	C	C	C	C	D	C	A
11	12	13	14	15	16	17	18	19	20
B	B	B	B	A	C	D	B	C	C
21	22	23	24	25	26	27	28	29	30
B	B	C	C	B	C	D	D	A	D
31	32	33	34	35	36	37	38	39	40
C	C	C	C	C	C	B	B	D	D
41	42	43	44	45	46	47	48	49	50
C	C	B	C	C	B	B	B	B	A

